



MuleSoft

MCPA-LEVEL-1-MAINTENANCE Exam

MuleSoft Certified Platform Architect - Level 1 MAINTENANCE

**Thank you for downloading MCPA-LEVEL-1-MAINTENANCE exam
PDF Demo**

**You can buy Latest MCPA-LEVEL-1-MAINTENANCE practice exam
software**

<https://www.certkillers.net/Exam/MCPA-LEVEL-1-MAINTENANCE>

Version: 4.0

Question: 1

Refer to the exhibit.

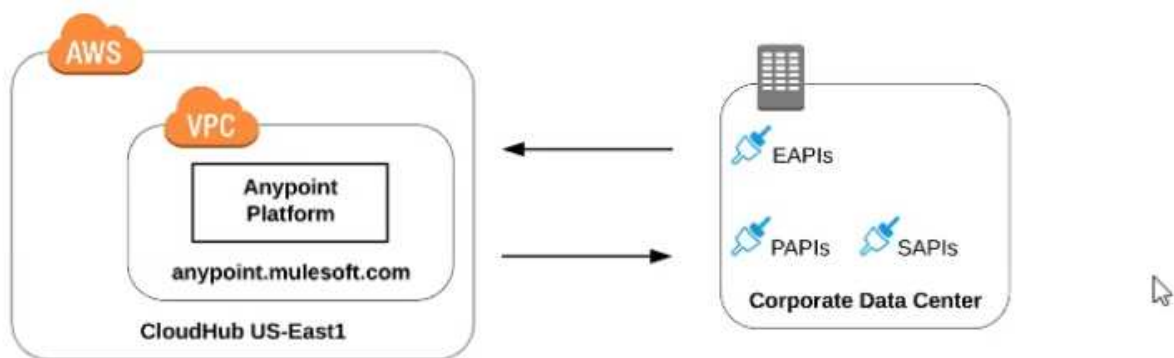

what is true when using customer-hosted Mule runtimes with the MuleSoft-hosted Anypoint Platform control plane (hybrid deployment)?

- A. Anypoint Runtime Manager initiates a network connection to a Mule runtime in order to deploy Mule applications
- B. The MuleSoft-hosted Shared Load Balancer can be used to load balance API invocations to the Mule runtimes
- C. API implementations can run successfully in customer-hosted Mule runtimes, even when they are unable to communicate with the control plane
- D. Anypoint Runtime Manager automatically ensures HA in the control plane by creating a new Mule runtime instance in case of a node failure

Answer: C

Explanation:

Correct Answer: API implementations can run successfully in customer-hosted Mule runtimes, even when they are unable to communicate with the control plane.

>> We CANNOT use Shared Load balancer to load balance APIs on customer hosted runtimes

- Load balancing

Load balancing is not provided for hybrid deployments. You can manage load balancing with the tools connected to your on-premises resources.

>> For Hybrid deployment models, the on-premises are first connected to Runtime Manager using Runtime Manager agent. So, the connection is initiated first from On-premises to Runtime

Manager. Then all control can be done from Runtime Manager.

>> Anypoint Runtime Manager CANNOT ensure automatic HA. Clusters/Server Groups etc should be configured before hand.

Only TRUE statement in the given choices is, API implementations can run successfully in customer-hosted Mule runtimes, even when they are unable to communicate with the control plane. There are several references below to justify this statement.

Reference:

<https://docs.mulesoft.com/runtime-manager/deployment-strategies#hybrid-deployments>

<https://help.mulesoft.com/s/article/On-Premise-Runtimes-Disconnected-From-US-Control-Plane-June-18th-2018>

<https://help.mulesoft.com/s/article/Runtime-Manager-cannot-manage-On-Prem-Applications-and-Servers-from-US-Control-Plane-June-25th-2019>

<https://help.mulesoft.com/s/article/On-premise-Runtimes-Appear-Disconnected-in-Runtime-Manager-May-29th-2018>

On-Premise Runtimes Disconnected From US Control Plane - June 18th 2018

Jun 19, 2018 · RCA

Content

Impacted Platforms

Impacted Duration

Anypoint Runtime Manager / On-Prem Runtimes

During this time frame, on-prem runtimes appeared disconnected from the US Anypoint Control Plane:

June 18, 2018 10:35 AM PST to June 18, 2018 11:12 AM PST

Incident Description

On-premises applications weren't able to connect to Anypoint Runtime Manager during the length of the incident, which made on-premises runtimes to throw errors in their logs because they received network disconnect messages from the control plane. Other than generating the log as mentioned above entries, on-premises runtimes and applications were not impacted.

=====

Runtime Manager cannot manage On-Prem Applications and Servers from US Control Plane - June 25th 2019

🕒 Jul 3, 2019 - RCA

Content

Incident Summary

Between 2:51 p.m. PT June 25th and 12:41 a.m. PT June 26th, customers were not able to manage their On-Prem applications and servers. The availability of running applications and runtimes were not impacted.

Impacted Platforms	Impact Duration
US-Prod	9 hours and 50 minutes

=====

On-premise Runtimes Appear Disconnected in Runtime Manager - May 29th 2018

🕒 Jun 2, 2018 - RCA

Content

Impacted Platforms	Impacted Duration
Anypoint Runtime Manager / On-Prem Runtimes	During this time frame, on-prem runtimes appeared disconnected from the US Anypoint Control Plane: Tuesday, May 29, 2018, 3:35 AM PDT to 4:27 AM PDT

Incident Description

During the incident time frame, managed Runtimes running on-premises disconnected from the US Anypoint Platform Control Plane and may have encountered recurrent re-connection errors. Customers were unable to manage applications running on those runtimes or register new ones during this time. Runtimes and Applications continued to operate without impact.

Question: 2

A System API is designed to retrieve data from a backend system that has scalability challenges. What API policy can best safeguard the backend system?

- A. IPwhitelist
- B. SLA-based rate limiting
- C. Auth 2 token enforcement
- D. Client ID enforcement

Answer: B

Explanation:

Correct Answer: SLA-based rate limiting

Explanation:

>> Client Id enforcement policy is a "Compliance" related NFR and does not help in maintaining the "Quality of Service (QoS)". It CANNOT and NOT meant for protecting the backend systems from scalability challenges.

>> IP Whitelisting and OAuth 2.0 token enforcement are "Security" related NFRs and again does not help in maintaining the "Quality of Service (QoS)". They CANNOT and are NOT meant for protecting the backend systems from scalability challenges.

Rate Limiting, Rate Limiting-SLA, Throttling, Spike Control are the policies that are "Quality of Service (QoS)" related NFRs and are meant to help in protecting the backend systems from getting overloaded.

<https://dzone.com/articles/how-to-secure-apis>

Question: 3

Refer to the exhibit.

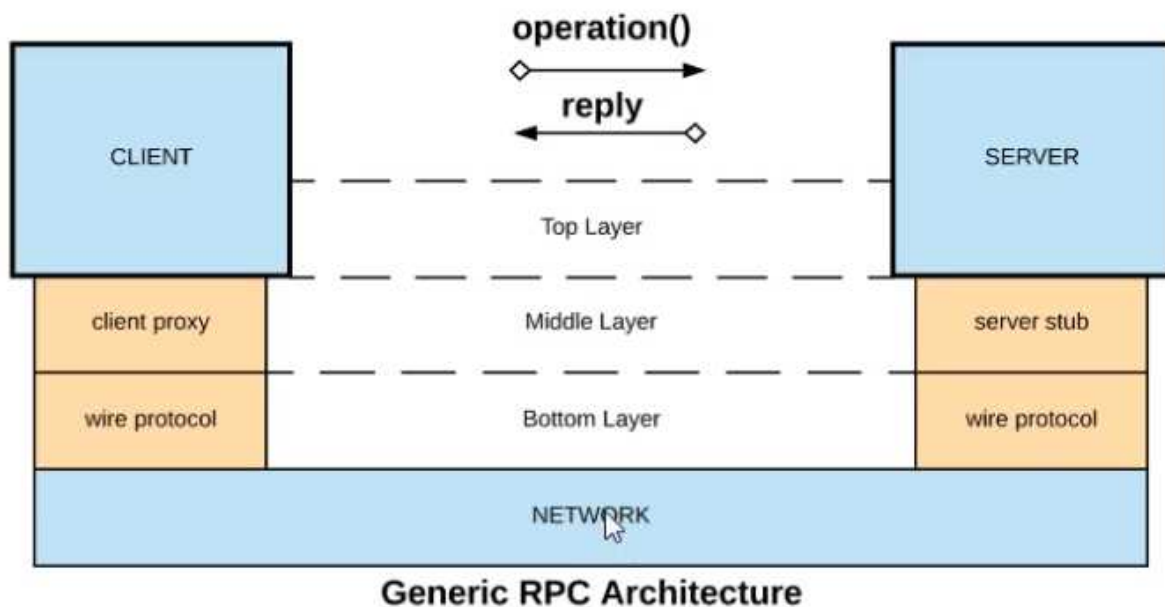

What is a valid API in the sense of API-led connectivity and application networks?

A) Java RMI over TCP

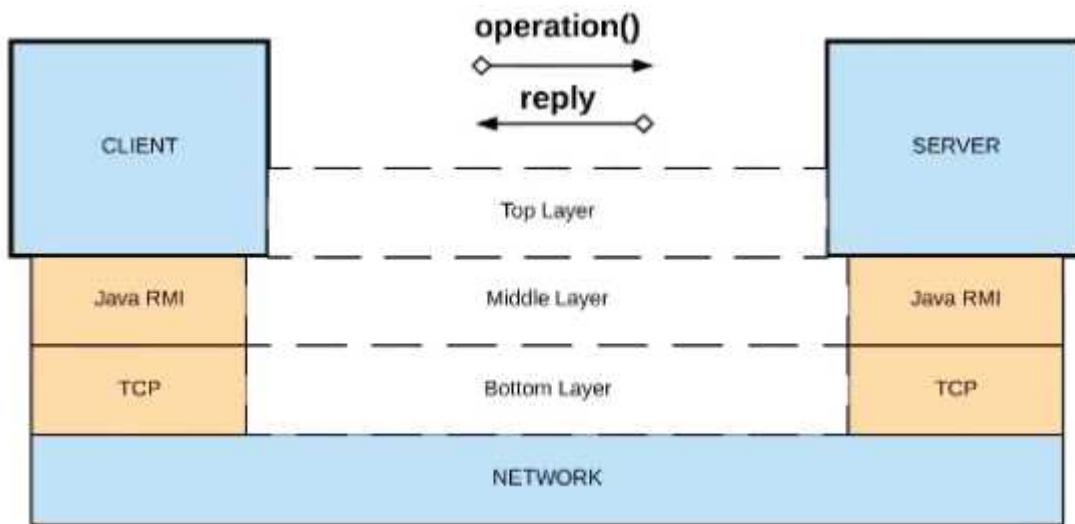

B) Java RMI over TCP

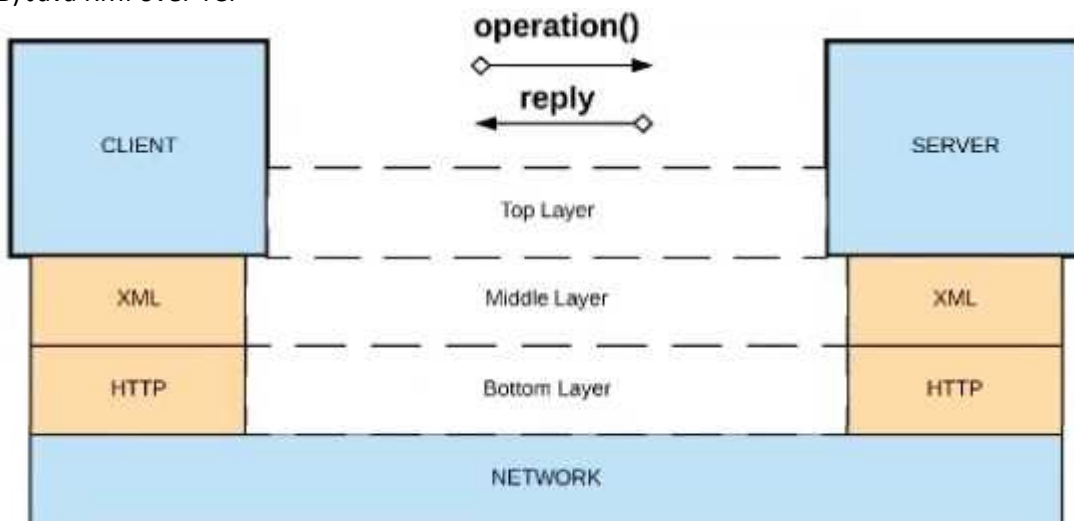

C) CORBA over HOP

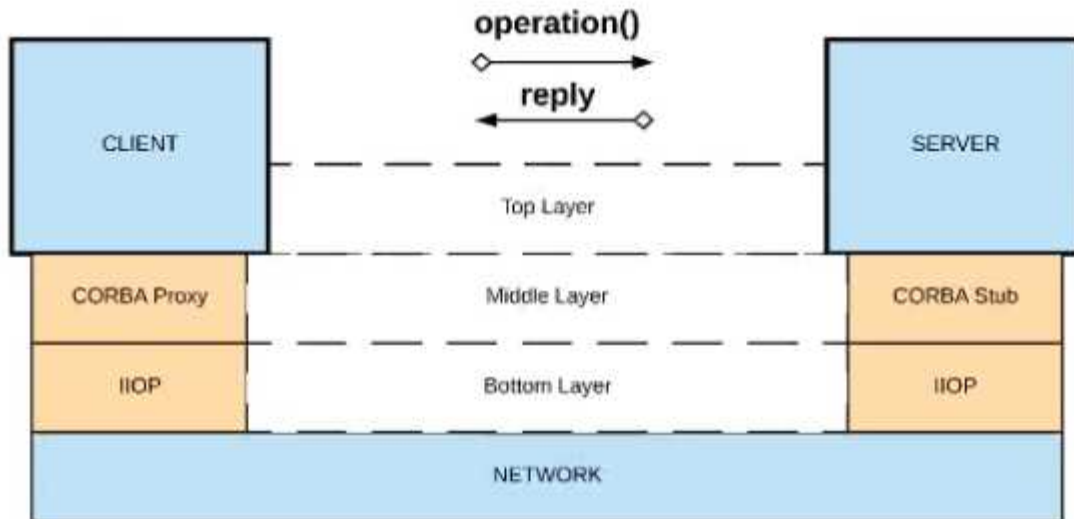

D) XML over UDP

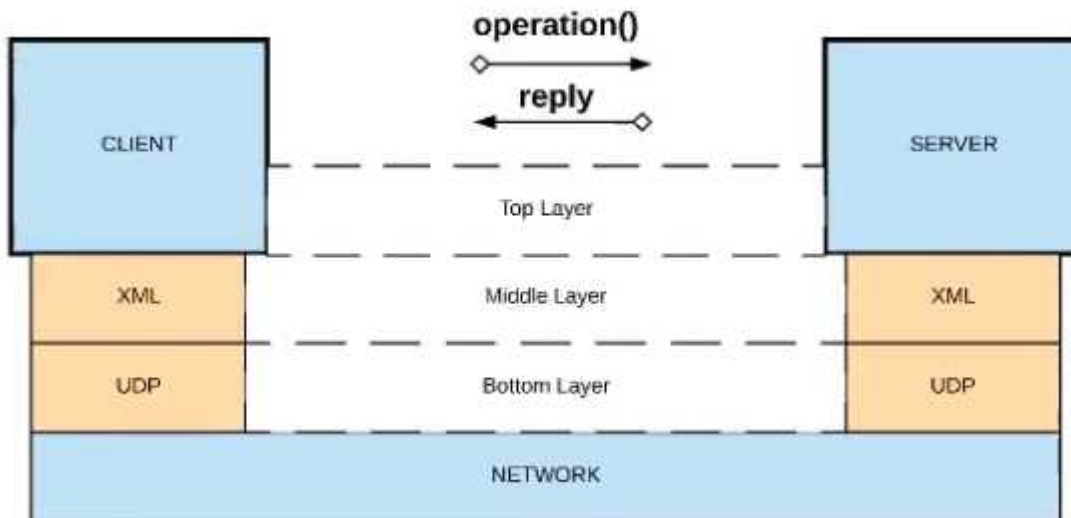

- A. Option A
- B. Option B
- C. Option C
- D. Option D

Answer: D

Explanation:

Correct Answer: XML over HTTP

Explanation:

>> API-led connectivity and Application Networks urge to have the APIs on HTTP based protocols for building most effective APIs and networks on top of them.

>> The HTTP based APIs allow the platform to apply various varieties of policies to address many NFRs
 >> The HTTP based APIs also allow to implement many standard and effective implementation patterns that adhere to HTTP based w3c rules.

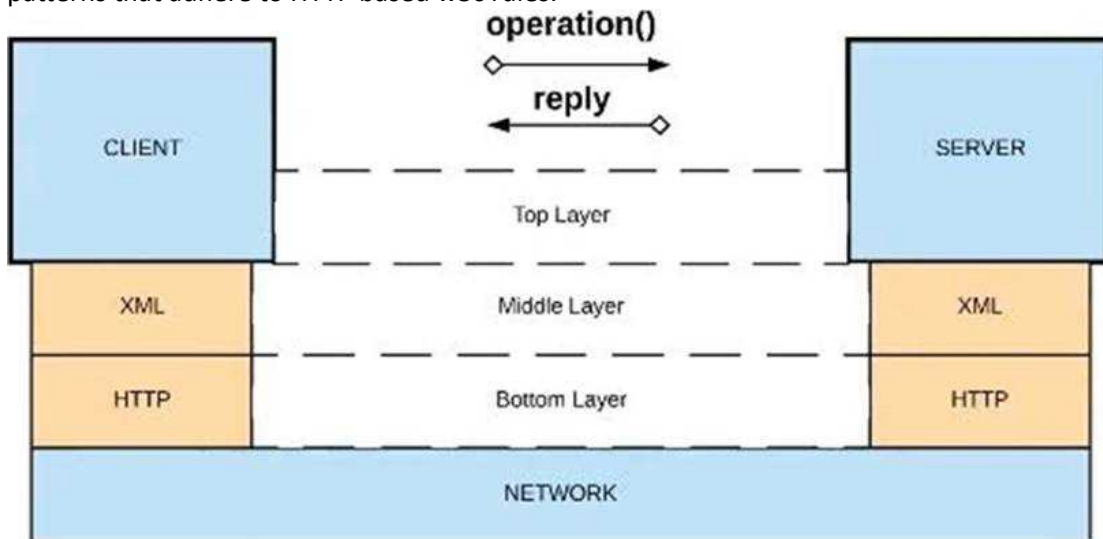

Bottom of Form
 Top of Form

Question: 4

Refer to the exhibit.

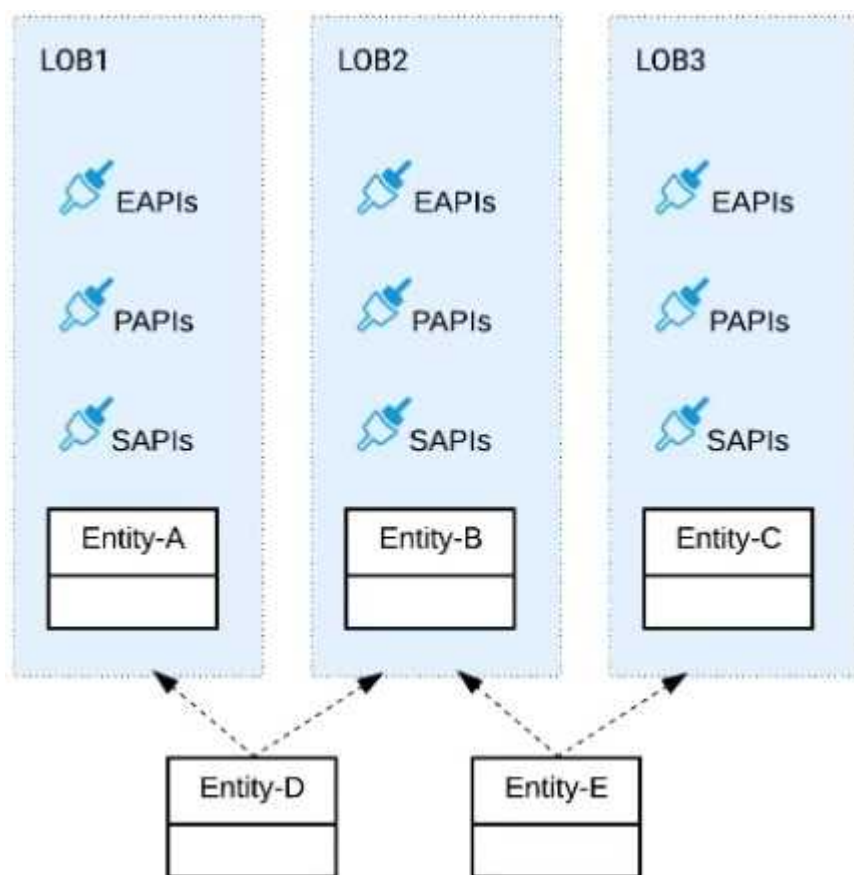

Three business processes need to be implemented, and the implementations need to communicate with several different SaaS applications.

These processes are owned by separate (siloes) LOBs and are mainly independent of each other, but do share a few business entities. Each LOB has one development team and their own budget

In this organizational context, what is the most effective approach to choose the API data models for the APIs that will implement these business processes with minimal redundancy of the data models?

A) Build several Bounded Context Data Models that align with coherent parts of the business processes and the definitions of associated business entities

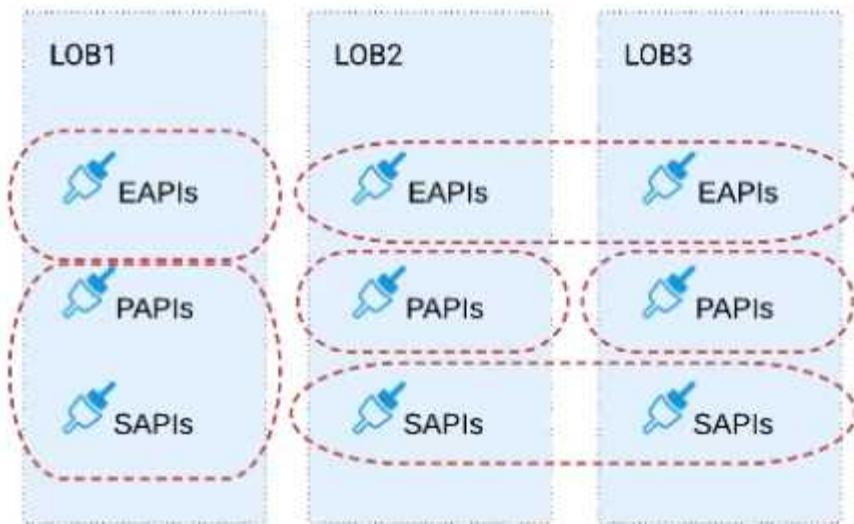

B) Build distinct data models for each API to follow established micro-services and Agile API-centric practices

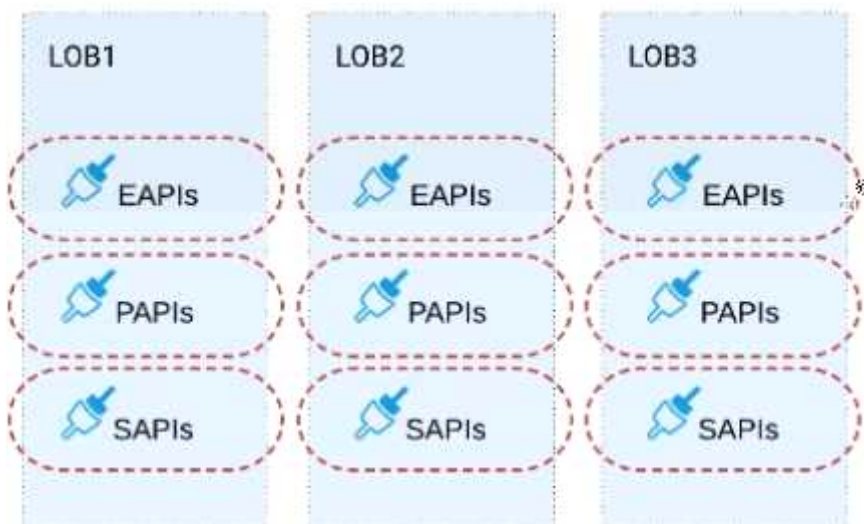

C) Build all API data models using XML schema to drive consistency and reuse across the organization

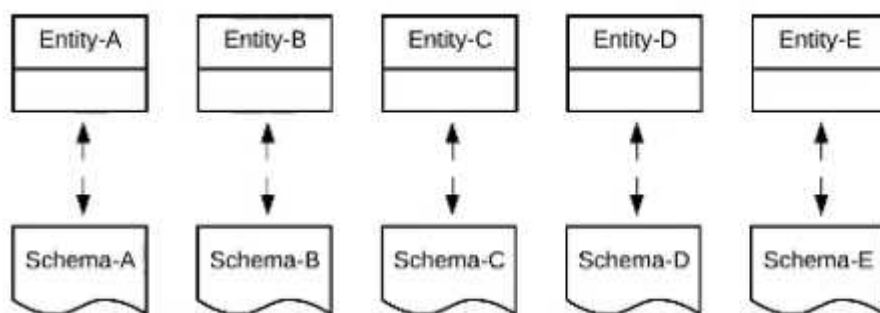

D) Build one centralized Canonical Data Model (Enterprise Data Model) that unifies all the data types from all three business processes, ensuring the data model is consistent and non-redundant

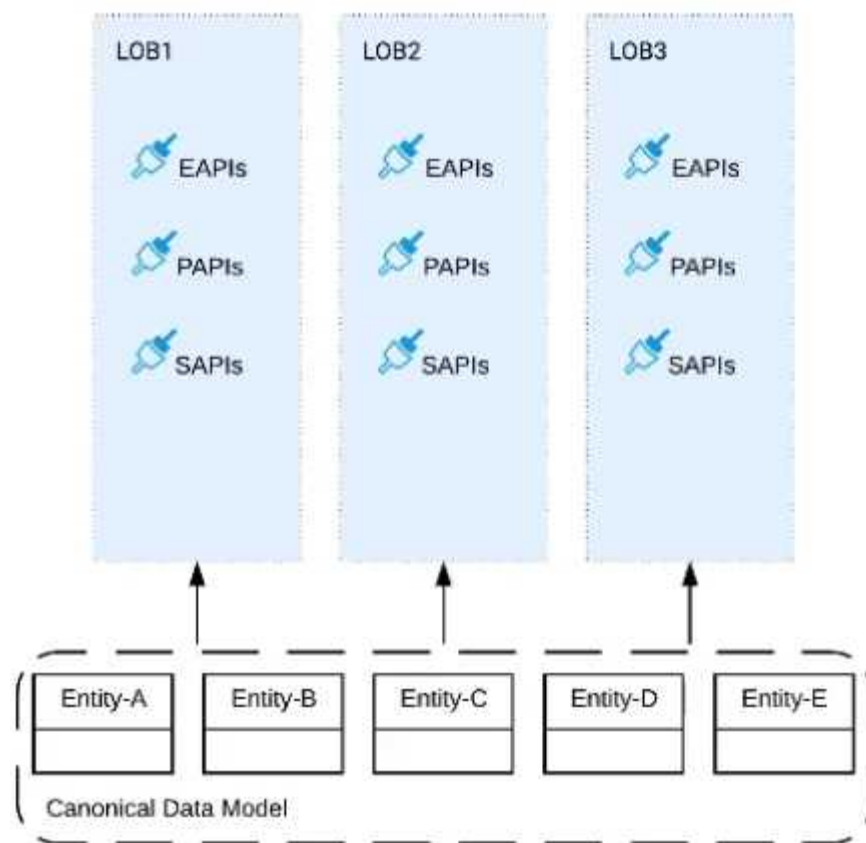

- A. Option A
- B. Option B
- C. Option C
- D. Option D

Answer: A

Explanation:

Correct Answer: Build several Bounded Context Data Models that align with coherent parts of the business processes and the definitions of associated business entities.

Explanation:of the business processes and the definitions of associated business entities.

>> The options w.r.t building API data models using XML schema/ Agile API-centric practices are irrelevant to the scenario given in the question. So these two are INVALID.

>> Building EDM (Enterprise Data Model) is not feasible or right fit for this scenario as the teams and LOBs work in silo and they all have different initiatives, budget etc.. Building EDM needs intensive coordination among all the team which evidently seems not possible in this scenario.

So, the right fit for this scenario is to build several Bounded Context Data Models that align with coherent parts of the business processes and the definitions of associated business entities.

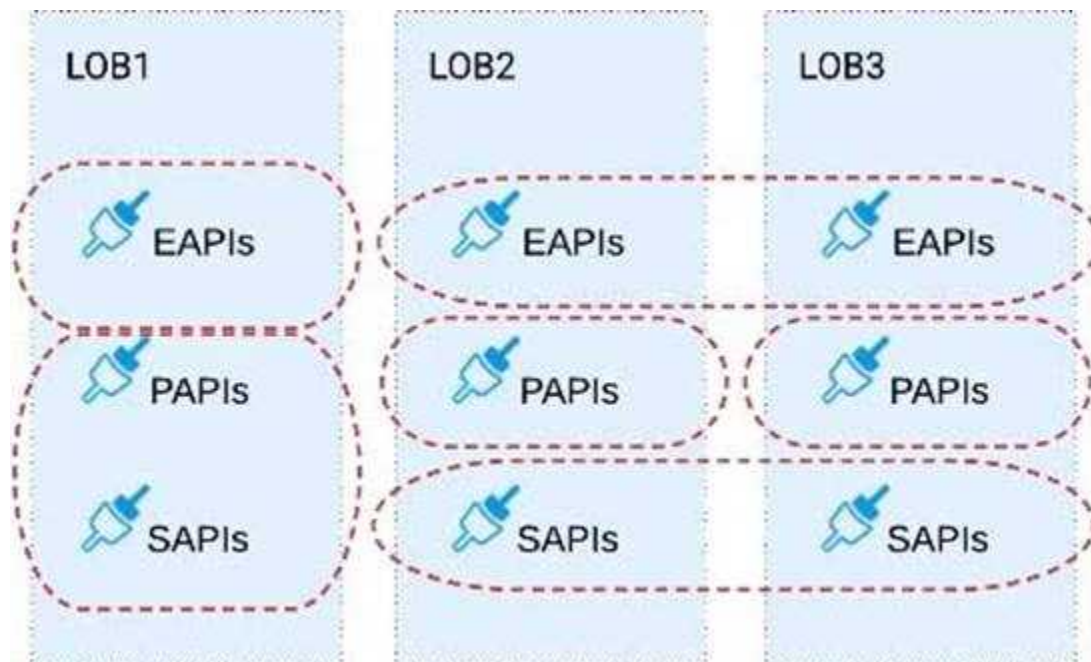

Question: 5

What best describes the Fully Qualified Domain Names (FQDNs), also known as DNS entries, created when a Mule application is deployed to the CloudHub Shared Worker Cloud?

- A. A fixed number of FQDNs are created, IRRESPECTIVE of the environment and VPC design
- B. The FQDNs are determined by the application name chosen, IRRESPECTIVE of the region
- C. The FQDNs are determined by the application name, but can be modified by an administrator after deployment
- D. The FQDNs are determined by both the application name and the Anypoint Platform organization

Answer: B

Explanation:

Correct Answer: The FQDNs are determined by the application name chosen,

Explanation:IRRESPECTIVE of the region

>> When deploying applications to Shared Worker Cloud, the FQDN are always determined by application name chosen.

>> It does NOT matter what region the app is being deployed to.

>> Although it is fact and true that the generated FQDN will have the region included in it (Ex: exp-salesorder-api.au-s1.cloudhub.io), it does NOT mean that the same name can be used when deploying to another CloudHub region.

>> Application name should be universally unique irrespective of Region and Organization and solely determines the FQDN for Shared Load Balancers.

Thank You for trying MCPA-LEVEL-1-MAINTENANCE PDF Demo

To Buy New MCPA-LEVEL-1-MAINTENANCE Full Version
Download visit link below

<https://www.certkillers.net/Exam/MCPA-LEVEL-1-MAINTENANCE>

Start Your MCPA-LEVEL-1- MAINTENANCE Preparation

Use Coupon “**CKNET**” for Further discount on the purchase of
Practice Test Software. Test your MCPA-LEVEL-1-MAINTENANCE
preparation with actual exam questions.